



Orders: 1-877-GO-HIPER
 Local: (785)-749-6011
 Fax: (785)-749-4760
 www.hiper-technology.com

Carbon Fiber Racing Wheels Assembly Instructions

Wheel Parts List:

Part	Quantity
Aluminum Center Section	1
Carbon Fiber Wheel Half	2
Carbon Fiber Bead-Lock Ring	1- Single Bead-Lock Wheel, 2- Dual Bead-Lock Wheel
Stainless Steel Bolt – ¼”-28 x 1.25	12
Stainless Steel Bolt – ¼”-28 x 1.00	12- Single Bead-Lock Wheel, 24- Dual Bead-Lock Wheel
Chro-Moly Steel Nut – ¼”-28	12
Valve Stem	1
Rubber O-Rings	2

Tools and Supplies Required:

- 3/8” Socket (12 point) (3/8” Drive)
- Ratchet and Extension (3/8” Drive)
- Cordless Drill with ¼” Drive attachment preferred.
- WD-40® Lubricant and/or liquid dish soap.
- Screw Driver or Tire Spoons (Recommended).

Torque Specs and Torque Patterns: (NOTE: DO NOT EXCEED TORQUE SPECIFICATIONS)

Center Section – Torque center section bolts with 3/8 ” drive ratchet, maximum 9 - 11 ft-lbs (108 – 132 in-lbs) in a two-stage star or criss-cross pattern.

Bead-Lock Ring – Torque bead-lock ring bolts with 3/8” drive ratchet, maximum 8 - 11 ft-lbs (96 – 132 in-lbs), using circular pattern will assist in aligning the bead.

Lug Nuts – Torque lug nuts to a maximum of 50 ft lbs.

Tire Mounting: Use Tire Mounting Lubricant on Non-Bead-Lock half when mounting the tire. WD-40® Lubricant and/or liquid dish soap will work also.

CAUTION: Do not exceed recommended tire pressure for seating the tire bead, and/or 25psi.

Returns: All Returns will require a return material authorization number (RMA). A return material authorization number is available from the HiPer Technology, Inc. Customer Service Department (785) 749-6011.

Exploded Wheel View:

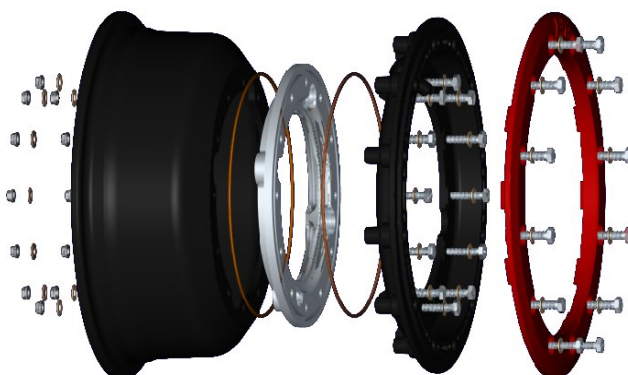

Tire Mounting Instructions

1. Generously apply tire mounting lubricant to the non-bead-lock half and the mating tire bead to aid in bead seating. Lubricants such as liquid dish washing soap or WD-40® work also.



2. Slip the bead of the tire under the bead-lock on one side and carefully pry the bead over the bead-lock with a tire spoon (DO NOT TWIST TIRE OVER BEAD-LOCK, DOING SO COULD RESULT IN A CUT BEAD AND A LEAKING TIRE).

3. Push the tire down onto the wheel and position the bead of the tire into the bead lock area.

4. Position the Bead-Lock Ring into the bead-lock and align the bolt- holes. Insert the 1" long bolts into the bolt-holes and secure finger tight. Make sure all bolts are started by hand before using wrench.

5. Tighten the bead-lock bolts using a 3/8" drive ratchet, in a two stage circular pattern. The first should just fix the bead into place. The second should be torqued to 96 - 132 in-lbs. The tire should be secured smoothly and evenly around the bead-lock. Look at the gap between the Bead-Lock Ring and the wheel half to make sure it is seated and even.



6. Apply more tire mounting lubricant to the non-bead-lock bead (if necessary), and inflate the tires to the recommended pressure for bead seating, approximately 25(+/-5) psi. **Do not over inflate.**

CAUTION: Do not allow fingers or hands to become inserted between the bead of the tire and the rim while seating.

Wheel Care Instructions

Aluminum Center Section: Use steel wool to remove any oxidation.

Main Body and Beadlock rings: Use soap and water to clean wheels and use Armor All ® to dress.

DISCLAIMER OF WARRANTY: PURCHASERS UNDERSTAND AND RECOGNIZE THAT MODULAR RACING WHEELS, FASTENERS OR BEADLOCK RINGS MANUFACTURED AND/OR SOLD BY HiPer Technology, Inc. (HEREINAFTER REFERRED TO AS "HiPer"), ARE EXPOSED TO MANY VARIED AND DIFFERENT CONDITIONS DUE TO THE MANNER IN WHICH RACING IS CONDUCTED. PURCHASERS ACKNOWLEDGE THAT RACING ALL-TERRAIN VEHICLES OR OTHER VEHICLES IS AN INHERENTLY DANGEROUS ACTIVITY THAT CAN STRESS AND DAMAGE THE BEST MADE PARTS AND EQUIPMENT, WHICH DAMAGE IN TURN, CAN CAUSE PROPERTY DAMAGE AND PERSONAL INJURY. PURCHASERS AND HiPer DESIRE TO MAKE THEIR BARGAIN AND PURCHASERS AGREE TO THE TERMS OF THIS DISCLAIMER IN GOOD FAITH AND IN CONSIDERATION FOR BEING ALLOWED TO PURCHASE FROM HiPer MODULAR RACING WHEELS, FASTENERS OR BEADLOCK RINGS. PURCHASERS EXPRESSLY ACKNOWLEDGE AND UNDERSTAND THAT HiPer DOES NOT MAKE ANY AFFIRMATION OF FACT OR PROMISE TO PURCHASERS WHICH RELATES TO THE MODULAR RACING WHEELS, FASTENERS OR BEADLOCK RINGS, THAT BECOMES A PART OF THE BASIS OF THE BARGAIN BETWEEN HiPer AND THE PURCHASERS, NOR DOES HiPer MAKE OR CAUSE TO BE MADE TO PURCHASERS, ANY DESCRIPTION OR AFFIRMATION OF FACT CONCERNING ANY SAMPLE OR MODEL OF HiPer MODULAR RACING WHEELS, FASTENERS OR BEADLOCK RINGS.

AS FURTHER CONSIDERATION FOR PURCHASERS USING HiPer MODULAR RACING WHEELS, FASTENERS OR BEADLOCK RINGS, PURCHASERS ACKNOWLEDGE THAT DUE TO THE DIFFERING CONDITIONS UNDER WHICH RACES ARE CONDUCTED AND THE DIFFERING SURFACES AND CONDITIONS TO WHICH MODULAR RACING WHEELS, FASTENERS OR BEADLOCK RINGS ARE EXPOSED AND SUBJECTED, PURCHASERS ARE NOT RELYING ON HiPer FOR ITS SKILL OR JUDGMENT TO SELECT OR FURNISH SUITABLE MODULAR RACING WHEELS, FASTENERS OR BEADLOCK RINGS FOR PURCHASE AND USE ON PURCHASERS' ALL-TERRAIN VEHICLE OR OTHER VEHICLE. PURCHASERS EXPRESSLY AFFIRM THAT THEY ARE RELYING ON THEIR OWN SKILL AND/OR JUDGMENT TO SELECT, PURCHASE AND INSTALL MODULAR RACING WHEELS, FASTENERS OR BEADLOCK RINGS SUITABLE FOR PURCHASERS' PURPOSES.

HiPer MAKES NO WARRANTIES WHATSOEVER, EXPRESSED OR IMPLIED, ORAL OR WRITTEN, TO PURCHASERS. THERE IS NO WARRANTY OF MERCHANTABILITY MADE TO PURCHASERS, NOR ANY WARRANTY OF FITNESS FOR A PARTICULAR PURPOSE WITH RESPECT TO MODULAR RACING WHEELS, FASTENERS OR BEADLOCK RINGS TO THE EXTENT PERMITTED BY LAW.

IT IS EXPRESSLY UNDERSTOOD AND AGREED BETWEEN PURCHASERS AND HiPer THAT AS A PART OF THE BARGAIN BETWEEN HiPer AND PURCHASERS, AND IN CONSIDERATION OF DOING BUSINESS WITH EACH OTHER, ALL PURCHASERS TAKE, SELECT, AND PURCHASE MODULAR RACING WHEELS, FASTENERS OR BEADLOCK RINGS FROM HiPer "AS IS" AND "WITH ALL FAULTS." PURCHASERS HAVE THE RIGHT TO INSPECT AND EXAMINE ANY MODULAR RACING WHEELS, FASTENERS OR BEADLOCK RINGS PURCHASERS CONTEMPLATE PURCHASING FROM HiPer AND PURCHASERS ACKNOWLEDGE THAT THEY HAVE EXAMINED AND INSPECTED ALL MODULAR RACING WHEELS, FASTENERS OR BEADLOCK RINGS PURCHASED FROM HiPer PRIOR TO INSTALLATION AND FOUND THEM TO BE IN GOOD WORKING ORDER. **PURCHASERS ASSUME ALL RISK AND RESPONSIBILITY ASSOCIATED WITH THE USE OF THESE PRODUCTS.**

IN THE EVENT THAT PURCHASERS EXPRESSLY OR IMPLIEDLY CAUSE REPRESENTATIONS, OR STATEMENTS, OR AFFIRMATIONS OF FACT CONTRARY TO THE TERMS OF THIS DISCLAIMER OF ALL WARRANTIES, EXPRESSED OR IMPLIED, THEN PURCHASERS AGREE TO INDEMNIFY AND HOLD HARMLESS HiPer FROM ANY CLAIMS, DEMANDS, SUITS, OR LEGAL ACTION AGAINST HiPer BY ANY SUBSEQUENT PURCHASERS.

IN CONSIDERATION OF BEING PERMITTED TO PURCHASE ANY HiPer MODULAR RACING WHEELS, FASTENERS, OR BEADLOCK RINGS PURCHASERS FURTHER AGREE THAT THIS IS THE ENTIRE AGREEMENT BETWEEN HiPer AND PURCHASERS AND NOTHING CONTAINED HEREIN SHALL BE CONSTRUED AS PART OF THIS DISCLAIMER OF WARRANTY.